

D221298749
D221298749

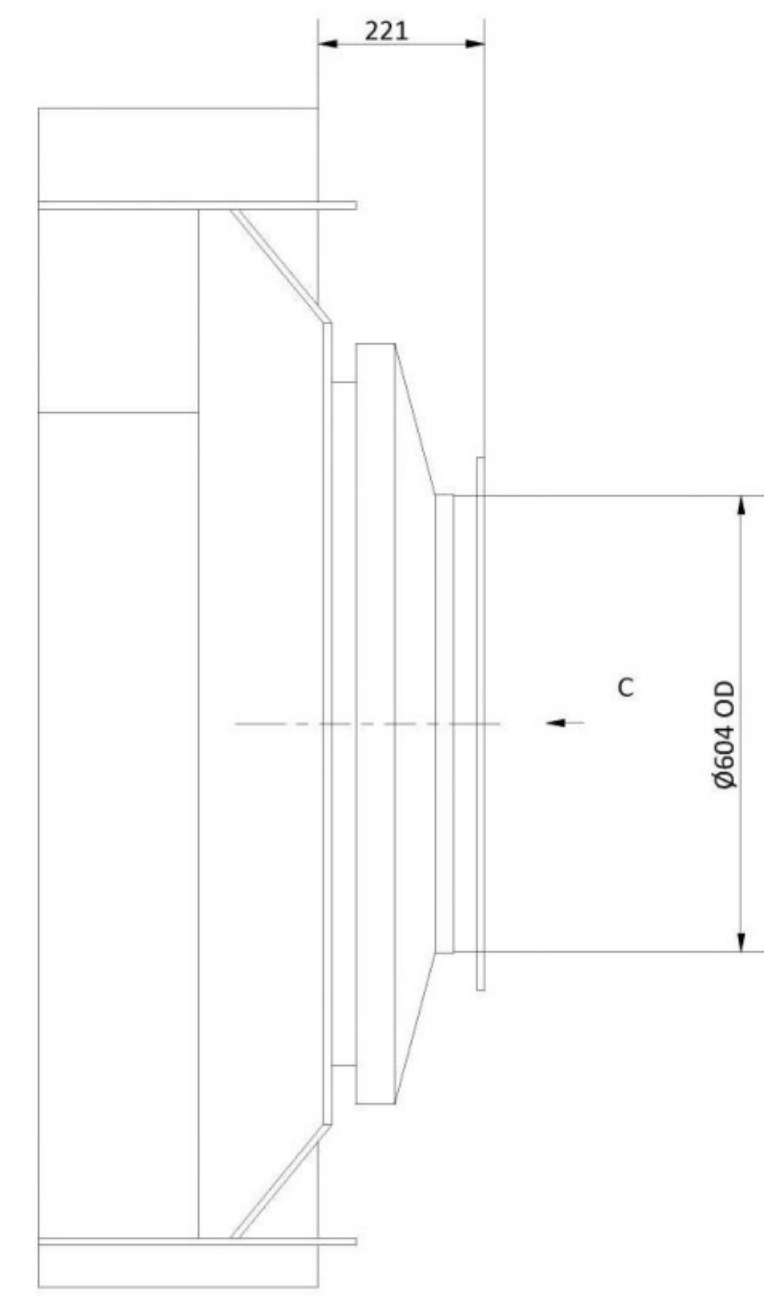

Dynamic shock absorber

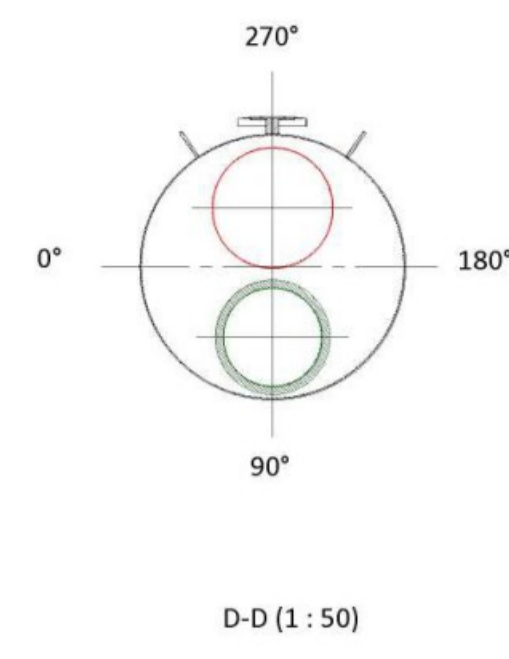
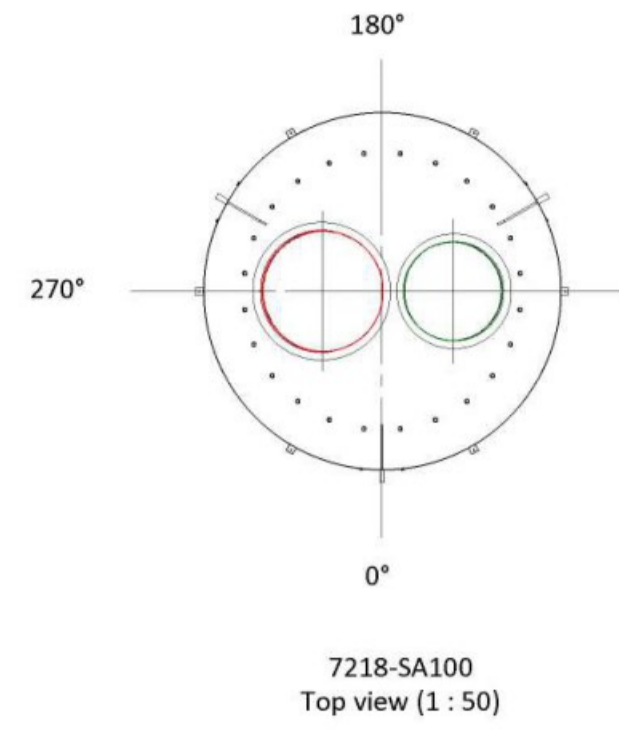
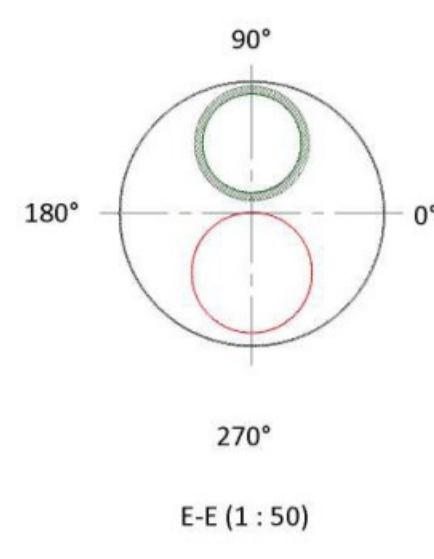
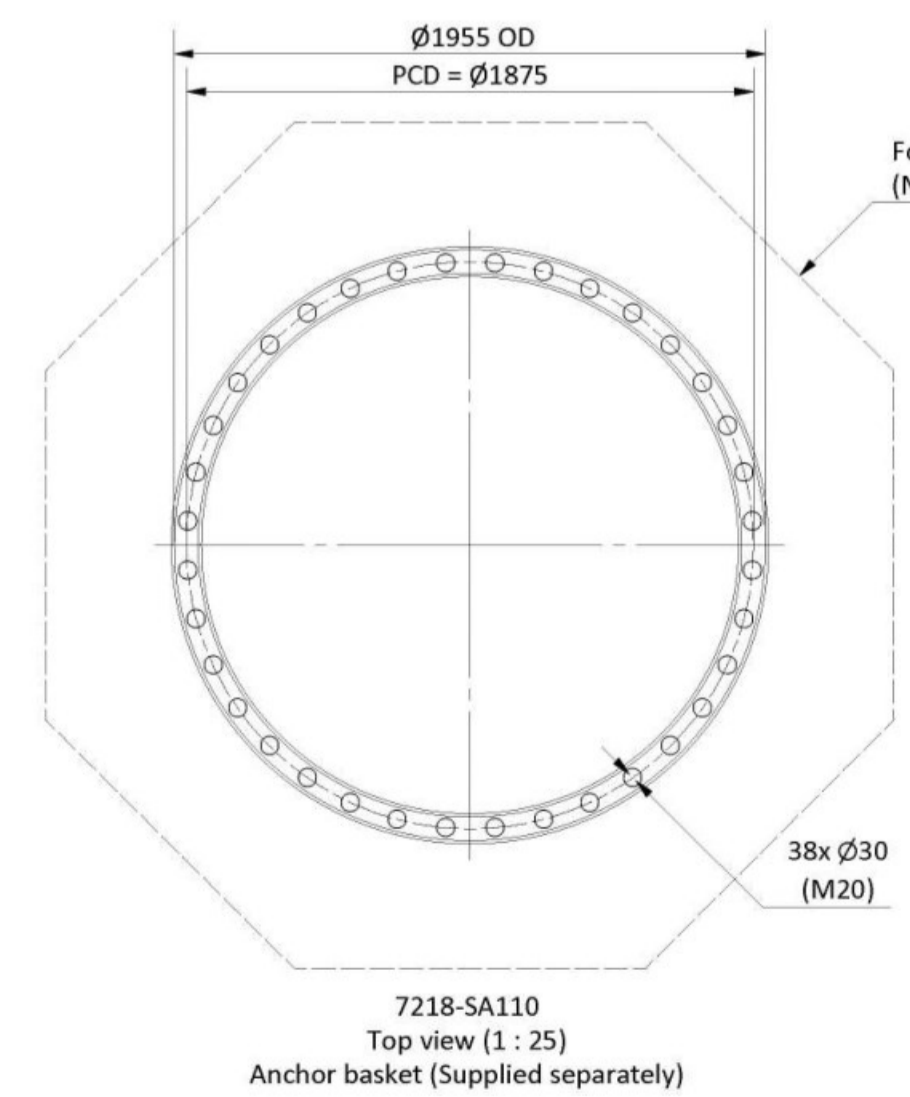
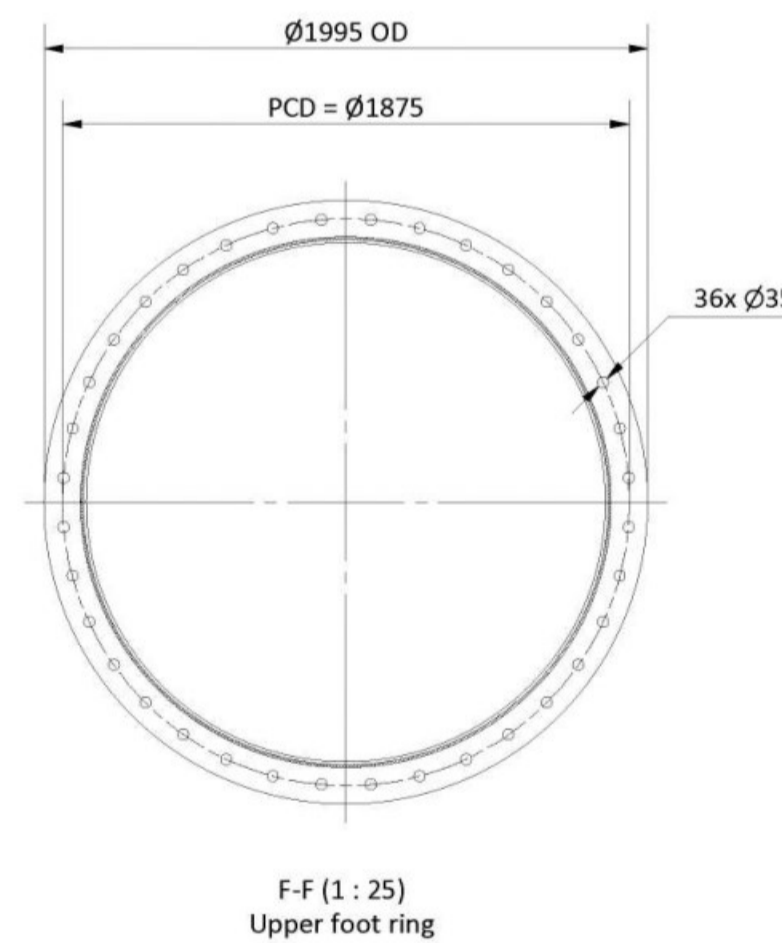
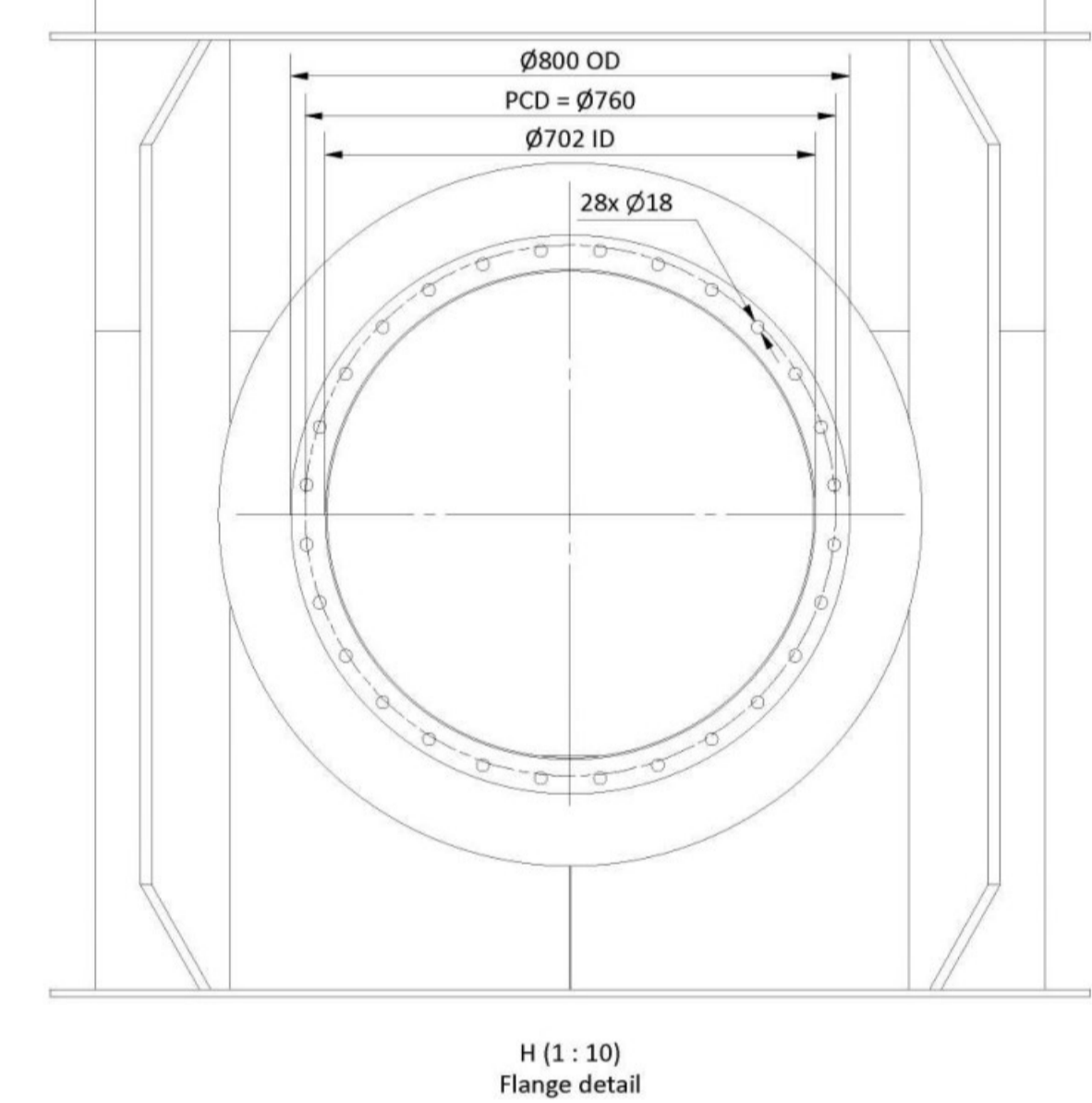
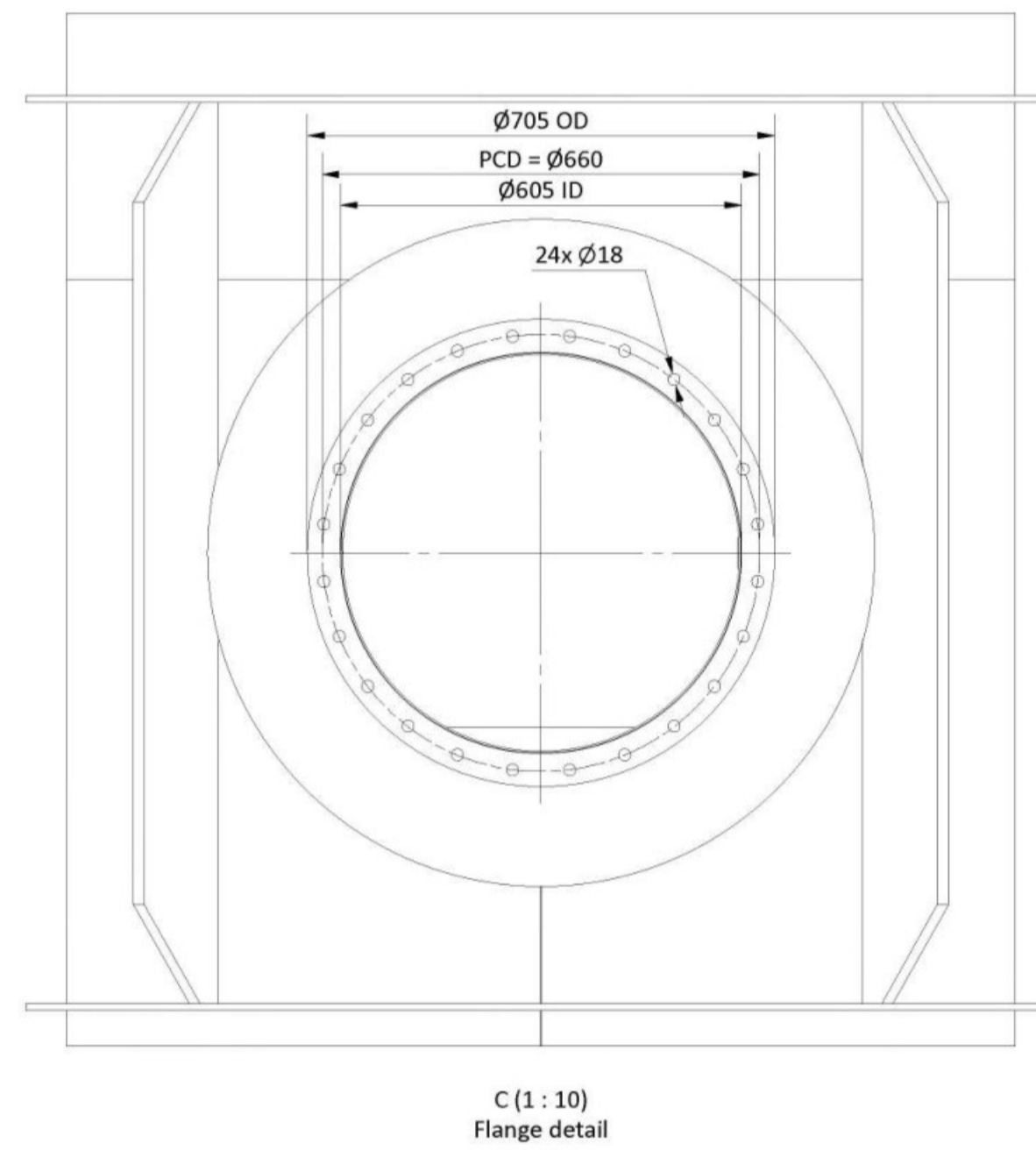
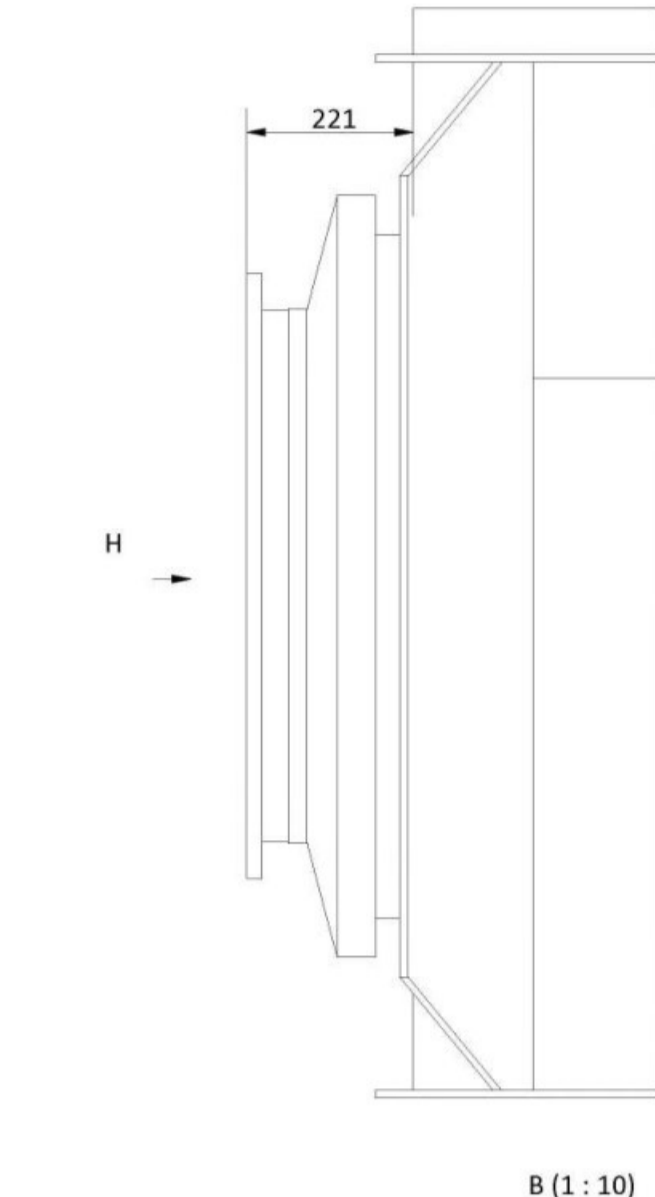
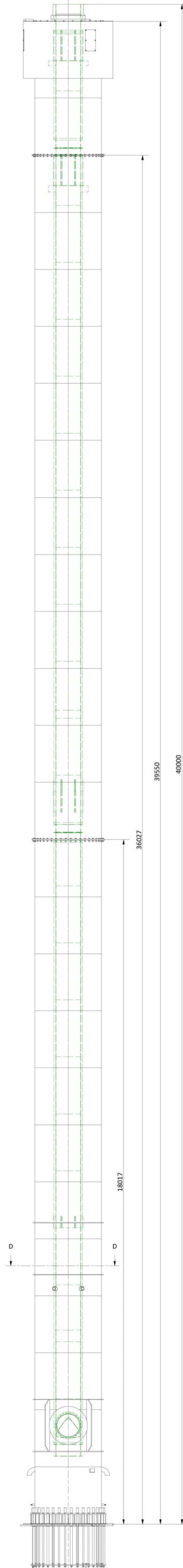
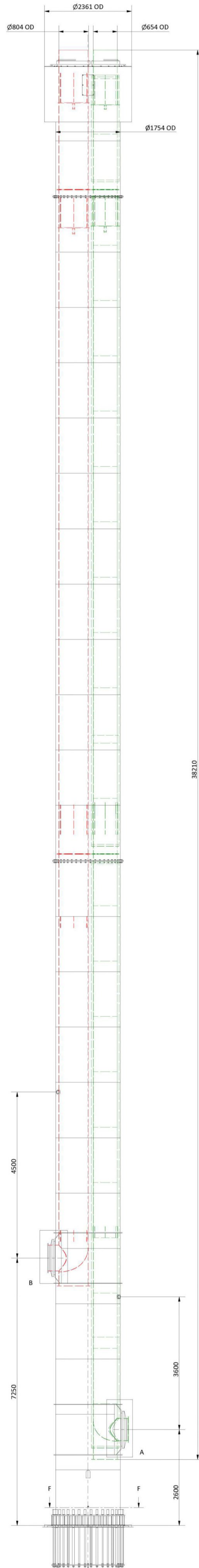
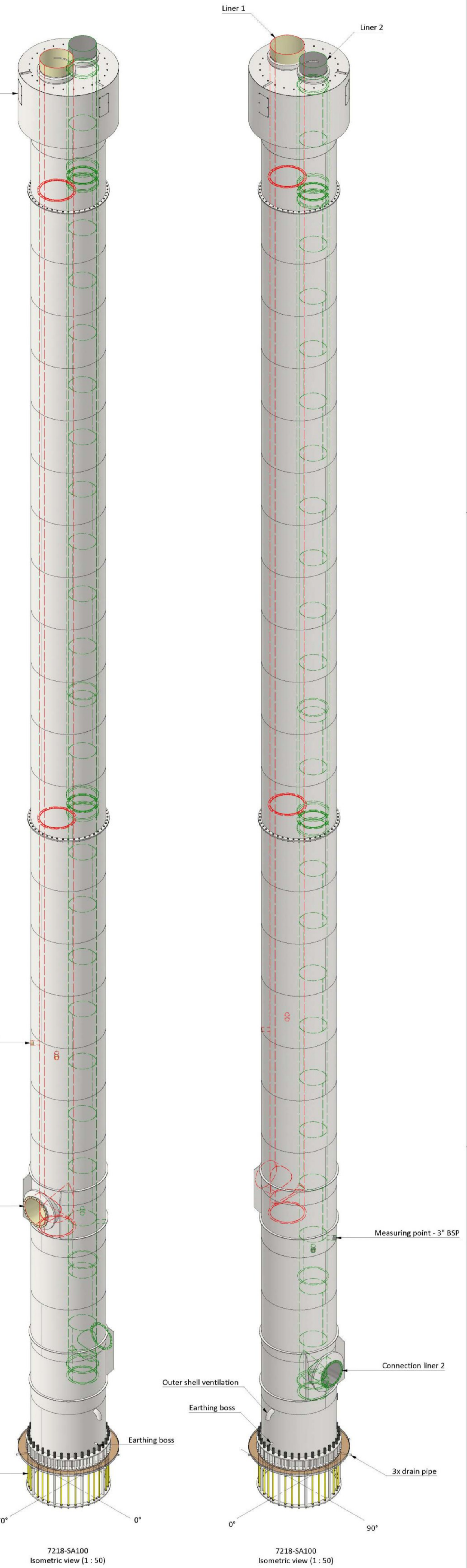

Foundation, for visualization only.
(Not in scope Bos Nieuwerkerk)

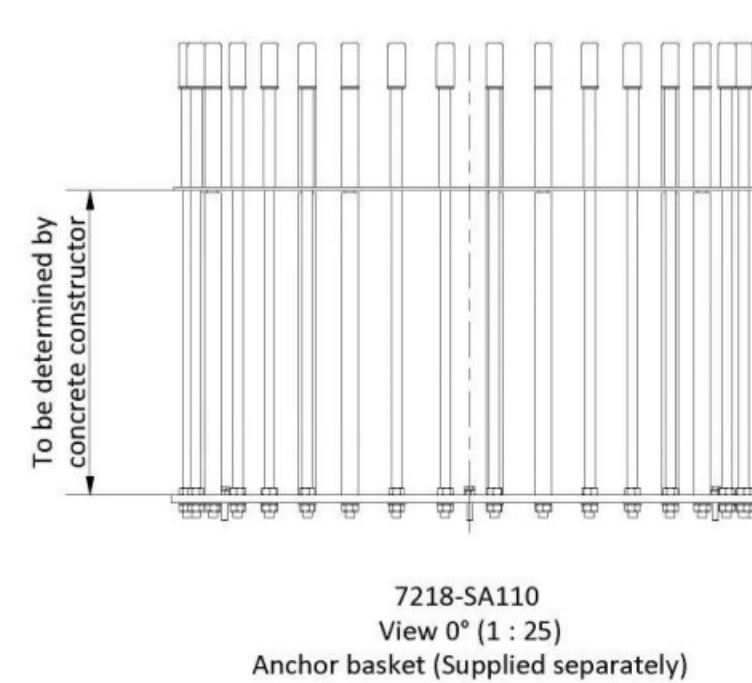

BN
B O S NIEUWERKERK
TER GOEDKEURING

NAAM	HANDTEKENING
Mariël Both	M. Both
15-12-2022	

- Notes:**
- Materials:
 - Outer shell: Steel S235JR (1.0038)
 - Liner 1: TBD
 - Liner 2: Stainless steel AISI904 (1.4539)

- Insulation:**
- Outer shell: n.a.
 - Liner 1: n.a.
 - Liner 2: 50mm Rockwool
- Conservation:**
- Outer shell: C4-H, end color RAL 7035 (outside only)
 - Liner 1: n.a.
 - Liner 2: Pickling and passivation (inside and outside)

- Weight:**
- Loose items:
 - Anchor basket: ±290kg
 - Dynamic shock absorber: 1705kg

- Chimney (inc liners):**
- Bottom piece: 17.300kg
 - Middle piece: 16.600kg
 - Top piece: 11.575kg
 - Total: 45.475kg

- Design temperatures:**
- Outer shell: 80°C
 - Liner 1: 30°C
 - Liner 2: 200°C

- Anchor basket:**
- More details in drawing 7218-SA110
 - Distance between top and bottom ring to be provided by 3rd party engineer
 - Anchor basket supplied separately

Rev.	Date	Drawn	Comments	Project information	Released by
A	14-12-2022	VT	For approval, changed after customer comments		MB
0	07-11-2022	VT	For approval		KL

Position	Outside	Surface treatment	See notes
Design temperature	See notes	°C	Inner coating
Operating temperature	See notes	°C	Outer coating
Design pressure	n.a.	Pa	1" 40µm Hempadar Avantgard
Welding acc. WPS	Yes		2" 120µm Hempadar Matic 6082W
N.D.T.	Yes (outer shell)	Color acc.	3" 60µm Hempadane HS 55610
Norm N.D.T.	EN 1090-2	Pickling/Passivating	See notes

Dimensions with tolerance ± 1 mm

All edges chamfered 0.3 mm

Holes on pitch and pitch/holes ± 1 mm

EN ISO 13920	2 1/4 30	31 1/4 120	121 1/4 400	401 1/4 1000	1001 1/4 2000	2001 1/4 4000	4001 1/4 8000
Measurment: C	± 1 mm	± 3 mm	± 4 mm	± 6 mm	± 8 mm	± 11 mm	± 14 mm

Department: Engineering, Assembling, Purchase, Steel, SS/Alum, Insulation, Ware house, Final Inspection

Date distribution: 2910 AE Nieuwerkerk a/d IJssel, T. +31 (0) 180 312388, info@schoorsteen.nl, www.schoorsteen.nl

General arrangement Chimney

Company: Sachem Europe B.V. Order no.: 18D22 Drawing no.: 7218-GA0 Rev.: A Size: A0

© Bos Nieuwerkerk B.V. 2022. Authors rights as established in our general terms and conditions of sales and delivery